

Joint European Research Infrastructure network for Coastal Observatories

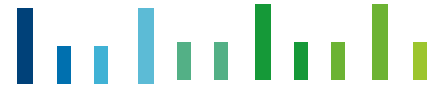

Report on Calibration Best Practices D4.2

Grant Agreement n° 262584

Project Acronym: JERICO

Project Title: Towards a Joint European Research Infrastructure network for Coastal Observatories

Coordination: P. Farcy, IFREMER, jerico@ifremer.fr, www.jerico-fp7.eu:

Authors: George Petihakis, Michael Haller, Wilhelm Petersen, Rajesh Nair, Jukka Seppälä, Florence Salvetat

Involved Institutions: HCMR, HZG, OGS, SYKE, IFREMER

Version and Date: V1.3 – 27/06/2014

Table of Contents



TABLE OF CONTENTS	3
1. DOCUMENT DESCRIPTION	6
2. EXECUTIVE SUMMARY	9
3. INTRODUCTION	11
4. MAIN REPORT	13
4.1. Temperature and Conductivity	13
4.1.1. The calibration procedure	13
4.1.2. Calibration Best Practice recommendations	14
4.2. Chlorophyll and Turbidity	18
4.2.1. Background	18
4.2.2. Measuring phytoplankton fluorescence	18
4.2.3. Chla fluorometers	20
4.2.4. Validation of Chla fluorescence	22
4.2.5. Calibration of Chla fluorometers	23
4.2.1. Calibration Best Practice recommendations	28
4.3. Chemical sensors	30
4.3.1. General aspects of best practises	31
4.3.2. Nitrate	34
4.3.3. Silicate	35
4.3.4. Phosphate	35
4.3.5. Ammonium	35
4.3.6. Nutrient calibration example	36
4.3.1. Calibration Best Practice recommendations	38
4.4. Oxygen sensors	40
4.4.1. Calibration and adjustment process:	40
4.4.2. Dissolved oxygen facility	43
4.4.3. The protocol of calibration	49
4.4.4. The adjustment process	51
4.4.5. Example of results	52
4.4.1. Calibration Best Practice recommendations	53

5. CONCLUSIONS

ANNEXES AND REFERENCES

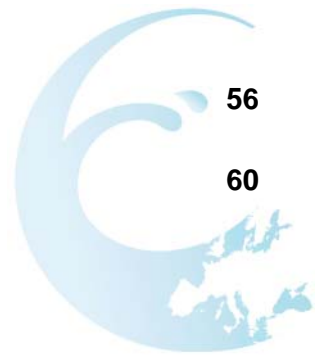



1. Document description

REFERENCES

Annex 1 to the Contract: Description of Work (DoW) version XX



Document information	
Document Name	Report on Calibration Best Practices
Document ID	
Revision	
Revision Date	17/10/2012
Author	George Petihakis, Michael Haller, Wilhelm Petersen, Rajesh Nair, Jukka Seppälä, Florence Salvetat
Security	

History			
Revision	Date	Modification	Author
1.0	30/04/14	Complete draft version	hzg, rn, js, fs
1.1	19/05/14	Modifications	gp
1.2	04/06/14	Further changes	js, fs, hzg
1.3	27/06/14	Modifications to final version	hzg, fs, rn, js

Diffusion list				
Consortium beneficiaries	X			
Third parties				
Associated Partners				

This document contains information, which is proprietary to the JERICO consortium. Neither this document nor the information contained herein shall be used, duplicated or communicated by any means to any third party, in whole or in parts, except with prior written consent of the JERICO Coordinator.

The information in this document is provided as is and no guarantee or warranty is given that the information is fit for any particular purpose. The user thereof uses the

information at its sole risk and liability.





2. Executive Summary

The main goal of work package 4 is to increase the performance of oceanographic observatories in Europe. One major point is the formulation and the evaluation of best practises of sensor calibration. This is an issue of great interest for institutions dealing with different (automated) observation systems.

So, this report is providing information about the best practises for sensor calibration of different types of sensors. Each sensor type has typical characteristics, which have to be addressed when calibration routine has to be applied to the sensor. This is outlined in the next sections for the different sensor types.

However, there are also several general advices for sensor calibration which are valid for any sensor when reliable sensor data are needed.

Temperature and conductivity sensors cannot be calibrated in the field, so thoroughly lab calibration is necessary, i.e. the preparing and maintaining of temperature baths.

For **Chlorophyll sensors** it is generally agreed that F_{Chla} measurements do not necessarily reflect true analytically measured [Chla], so this has to be taken into account when calibrating chlorophyll fluorescence sensors. No generally accepted method for fluorometer calibration exists, so also manufacturers have different conventions. Various solutions for primary fluorometer calibration include factory calibration, use of algae cultures, chemical standards dissolved in water or in various solvents, or solid standards.

Calibration of **chemical sensors** relies strongly on proper handling of water samples and reagents and the preparing of standard solutions. Monitoring of more than one nutrient parameter with one device has to be carried out carefully.

For **oxygen sensors** the according calibration routine relies on comparing lab analyses via Winkler titration which needs some experience to carry out including proper sampling. A wide range of different concentration levels and different temperature levels must be used for calibration of optical oxygen sensors.





3. Introduction

Reliable calibrations of instruments require well-established, documented procedures, specialized instrumentation, certified or recognized reference material (where these are available), dedicated laboratory facilities, trained personnel, and proven expertise. Although sensor calibration is absolutely crucial for good quality data, it is also a rather difficult task since different sensors have completely different requirements (time intervals) and methodologies.

There are two major problems; shipping sensors to manufacturers on regular basis which is neither convenient nor cost efficient and maintenance intervals that have to be planned according to the requirements of each sensor (need for double sets of sensors). Thus transport and calibration costs often have a major contribution on total running costs. Although there is significant experience among European research institutes on calibration methods, at present each lab works independently with no or very little connections with other labs. As described in the Description of the Work document, a major aim within JERICO is to:

- Standardize and harmonize various facilities across European networks,
- Share existing calibration facilities within the network, thus significantly reducing costs,
- Exchange and transfer know-how within the network through a series of workshops, seminars and staff exchange.

Operation and maintenance activities are probably the most crucial elements in the life-cycle of a research infrastructure and in some cases even more demanding than the design and construction of the infrastructure itself.

A sensor is only as good as its calibration, so a good sensor produces only poor results if the calibration is insufficient. Good sensors observations require both reliable sensor measurement methods and reliable



calibration procedures. The successful implementation of operation and maintenance activities guarantees the good performance of the infrastructure and the protection of the investment. Coastal observatories have been developed in Europe in a rather uncoordinated way. Usually based on national funding and priorities, these observatories have very diverse design and architecture and have established very different practices for their operation and maintenance. For certain subsystems (e.g. FerryBox), past EU projects have established a network of operators through which experience and best practices have been shared but this is not the case for other observing platforms, and certainly not for integrated coastal observatories. Therefore, more work is needed to gather and combine information of relevant calibration issues.

The term *calibration* is defined as an operation that establishes a relation between the quantity values with measurement uncertainties provided by measurement standards and corresponding indications with associated measurements uncertainties and, in a second step, uses this information to establish a relation for obtaining a measurement result from an indication (JCGM, 2012).

Sometimes, however, the word *calibration* is misused to describe the process of altering the performance of an instrument to ensure that the values it indicates are correct within specified limits (e.g. adjusting an instrument until its reading agrees with that of another instrument). Strictly this is adjustment - defined as the operation of bringing a measuring instrument into a state of performance suitable for its use - and not calibration, although the nature and magnitude of the adjustment is often determined by a pre-adjustment calibration, sometimes known as an *as found* calibration (NPL, 2014).

After reporting on existing calibration facilities and their equipment in JERICO deliverable 4.2, this report is a guide to suggested best practise in performing sensor calibration. It gives advice on laboratory practise for all surrounding procedures.

Information of best practise are gathered and analysed to new calibration strategies to improve the overall performance and efficiency of European oceanographic measurements of different sensor types in the future. For the proposal of common practises a close cooperation with work package 3, as calibration matters are depending on the measuring platform. They are addressed in WP 3 which is evaluating the state of the art of underway platforms (i.e. FerryBoxes), Gliders and Fixed Platforms.



4. Main Report

4.1. Temperature and Conductivity

4.1.1. *The calibration procedure*

Marine temperature (T) and conductivity (C) sensors are calibrated by immersing them in a thermostatic temperature calibration bath filled with seawater in a climate-controlled laboratory or facility. The bath is cycled down through the complete oceanographic temperature range in step changes from high to low temperatures in order to provide calibration set-points where sensor readings and comparable reference temperature and conductivity values are acquired. At each temperature set-point, a reference temperature value is estimated from a set of readings made using a calibrated Standard Platinum Resistance Thermometer (SPRT), the only acknowledged ITS-90 interpolating instrument, coupled with an AC or DC precision thermometry bridge (see Figure 4.1.1).

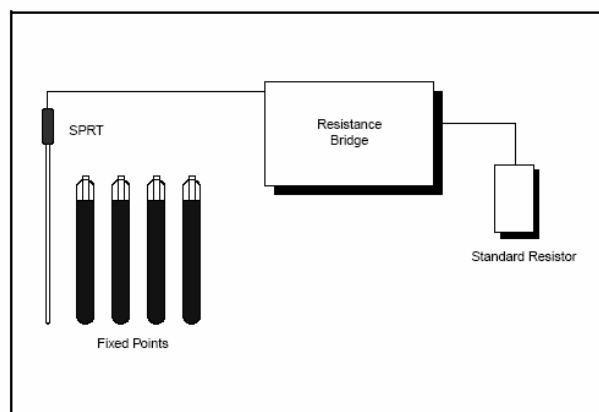



Figure 4.1.1: Testing of unit in thermostatic bath, controlled with reference system (left). Reference system for temperature using ITS-90 fixed points (right).

A reference conductivity value corresponding to the specific reference temperature is obtained by inverting the measured salinity from water samples collected after the SPRT and the T and C sensor measurements are completed. The salinity determinations are usually carried out using a Laboratory Salinometer, standardized with IAPSO Standard Seawater. The data collected at the different temperature and conductivity set-points are employed to evaluate the T and C sensor performances in the testing range, and compute new calibration coefficients if needed.

Marine T and C sensors cannot be calibrated in the field; field checks serve, at best, to monitor the effective operating characteristics of the sensors.

Further details of T and C sensor calibration can be found by e.g. Mantylaa (1987); Millero et al. (2008); NIST (1990); Saunders (1990).

4.1.2. Calibration Best Practice recommendations

- The proper calibration of T and C sensors requires expertise, specialized equipment and procedures, dedicated staff, and most of all experience. If these resources are lacking in-house, it is better to send the sensors to the manufacturer for calibration or avail of an external provider of similar services.
- Temperature calibration baths in titanium or any other suitably inert material (for example, plastic) are recommended for use with seawater to reduce the dangers of corrosion-related problems.
- All the elements of the reference measuring systems must be maintained to within declared specifications by monitoring their performances regularly, adhering to recommended usage and upkeep practices, and scheduling servicing with a manufacturer immediately when laboratory quality assurance procedures indicate a developing problem.



- It is wise to keep an externally calibrated, certified SPRT to use as an independent temperature reference for comparisons if needed; such an SPRT can also serve as a surrogate standard resistance to help check thermometry bridge performance if proper reference resistors are unavailable.
- The Laboratory Salinometer must be standardized using a bottle of IAPSO P-Series Normal Standard Seawater (salinity = 35 psu) prior to every salinity sample analysis run. A bottle of IAPSO 38H-Series High Salinity Standard Seawater (salinity = 38 psu) must be measured immediately after standardization to determine instrument offset and linearity in the high range if samples with high salinities are expected. The standardization and the offset and linearity checks should be always repeated every 24 hours. A full-scale linearity check of the salinometer ($10 \text{ psu} \leq \text{salinity} \leq 38 \text{ psu}$) should be performed at least once every six months in-between returns to the factory employing IAPSO P-Series, 10L-Series (salinity = 10 psu), 30L-Series (salinity = 30 psu) and 38H-Series Standard Seawaters.
- Sensors should be visually inspected prior to calibrating.
- The temperature calibration bath should be allowed to settle at a calibration set-point for a sufficient period of time (an hour or more) before sampling is initiated. The stability of the bath should be continuously monitored during the sampling interval.
- The calibrated sensors should be checked at least at a few calibration set-points prior to releasing them for duty. In the case of conductivity, seawater with different salinities could be used in the bath to obtain the necessary calibration set-points although this practice is not commonly followed.
- In principle, reference T and C measurements could be acquired using internal transfer standards (for example, a C-T sensor couple) in lieu of a SPRT and a Laboratory Salinometer, provided traceability to the appropriate primary standards has been established and the quality of readings are compatible with the degree of uncertainty required for calibrating.



- Marine T and C sensors require regular, often frequent, calibrations because their performances tend to vary over time and can be affected in different ways by specific conditions of usage and/or storage. Sensor calibrations need to be verified at least once a year.
- Proper field maintenance is the key to successful calibrations. Poorly maintained instruments often need to be subjected to long and complicated procedures in order to restore them to a condition that would permit a proper calibration to be performed.
- In the case of modular T and C sensors, sensor calibrations must be performed, wherever possible, employing the main housing containing the electronics of the instrument to which they belong.
- Sensors should be subjected to an “as received” evaluation of their performances prior to adjustment. The information thus obtained could be useful for adjusting collected data to account for sensor drift or errors during deployment.
- It may be useful to occasionally employ a calibration service provider different from the usual one; for example, if calibrations are routinely performed in-house, they could be done externally every once in a while. Over time, this custom will provide information useful for quality assurance.
- Calibration records must be kept up-to-date; calibration histories of sensors can often help to pre-empt potential problems with them in time.
- The results of a calibration may or may not be accredited but they must always be accompanied by the following:
 - A declaration of the uncertainty associated with the calibration process;
 - Information evidencing traceability to reference material (certified or otherwise): ITS-90 fixed points for temperature and IAPSO Standard Seawater for conductivity.
- If possible, choose calibration facilities and providers that actively pursue a policy of continuous and open assessments of the quality of their services through initiatives such as inter-comparison



exercises, laboratory evaluation schemes, etc.



-

4.2. Chlorophyll and Turbidity

4.2.1. Background

Chlorophyll *a* (Chla) fluorescence of living phytoplankton (F_{Chla}) has been used as a proxy of Chla concentration ($[\text{Chla}]$) for decades. Development of new instruments towards low-cost miniaturized sensors has increased the popularity of the method, though basic measuring principle is still the same as in 1960's. Despite the long history of the method, typically the primary optical calibration of instruments has not been considered as an important issue, but most of the attention has been paid in the validation of the fluorescence signal with analytical $[\text{Chla}]$ measurements using field samples.

Overall objective of this chapter is to describe how we could improve the information content of chlorophyll fluorescence measurements. Including auxiliary measurements describing variability between F_{Chla} and $[\text{Chla}]$ has been recognized as one option. It will be, however, partly wasted effort unless the frequent and precise primary calibration of chlorophyll fluorometers is carried out. Having consistent and comparable fluorometer data, after such calibration, allow collecting spatially and temporally (and ecologically) relevant data-sets for further analysis.

4.2.2. Measuring phytoplankton fluorescence

In phytoplankton cells, various pigments absorb light at their specific wavelengths. Qualitatively pigmentation is constrained by the evolutionary history of the species, while quantitatively pigmentation is largely controlled by environmental conditions the cells are acclimated to. Common to all phytoplankton species, Chla plays a major role in the functioning of photosystems.

In cells, Chla cannot be found as free molecules, but it is located in either photosystem II (PSII) or photosystem I (PSI). Each of these photosystems consists of light harvesting antenna pigments and reaction centres. Light harvesting pigments collect light energy and transfer it rapidly towards Chla molecules in the



reaction centres, which are sites for the primary photochemical reactions. In the case photochemistry is blocked, for some reason, part of the energy will be dissipated as heat, it may be passed to another photosystem or back to antenna pigments, or it may be fluoresced by Chla molecules located in reaction centre or in the antenna.

The main source of F_{Chla} are Chla molecules in the antenna of PSII, as they are more numerous than Chla molecules in reaction centres. PSI fluorescence is very low, as due to energetic reasons the light energy entering PSI reaction centre cannot be passed back to the antenna.

It is well acknowledged that F_{Chla} measurements do not reflect true analytically measured [Chla]. The reasons for this discrepancy are manifold:

- F_{Chla} arise mainly from photosystem II, while part of the cellular Chla is located in non-fluorescing photosystem I. This ratio between fluorescing/non-fluorescing Chla varies between phytoplankton species and groups. While most eukaryotic species show quite balanced distribution, in cyanobacteria most of the Chla (80-90%) can be found at photosystem I, thus these organisms show low F_{Chla} relative to their [Chla] (Johnsen and Sakshaug 2007).
- Photochemistry affects magnitude of F_{Chla} . During high photosynthetic activity more of the absorbed light energy is used in photochemical reactions and less is fluoresced. The dependence of F_{Chla} on photochemical state is called photochemical fluorescence quenching. A typical example is an increase of the ratio between F_{Chla} to [Chla] due to nitrogen limitation of photosynthetic rate.
- The increase of heat dissipation in photosystem II, for example due to exposure of cells to excessive irradiance levels, may also decrease F_{Chla} (Babin 2008). This phenomenon is called as non-photochemical fluorescence quenching, and it consists of several types of quenching with different origin and relaxation kinetics. Most outstanding example of non-photochemical fluorescence quenching is a decrease of ratio between F_{Chla} to [Chla] when a water sample is exposed to direct sunlight.
- The magnitude of F_{Chla} is also affected by the pigment packaging and light re-absorption (Babin 2008). In the case of highly pigmented cells (e.g. grown in low light) the light absorption rate per Chla molecule decreases due to self-shading, thereby also decreasing the probability of fluorescence emission. On the other hand, if the pigments are densely packed in the cells, re-absorption of the



fluoresced light by neighbouring Chla molecules decreases the amount of F_{Chla} detected.

For the above reasons the ratio between F_{Chla} and $[\text{Chla}]$ may vary theoretically at least 50-fold. Quite often, the observed variability during specific field studies is 2-4 fold.

4.2.3. Chla fluorometers

Fluorescence is a relative measurement, without physical units. Typically fluorescence readings are shown as “voltage” measured by detector, or as “bits” after it has been converted to digital form, or more simply using units like “relative fluorescence units, RFU” or “arbitrary units, AU”. Some instruments read out values like “ $\mu\text{g/l}$ ”, trying to imply that real concentration measurement is carried out, though it simply means that instrument may have been calibrated by the manufacturer. It is important to understand that such calibration is valid only for the material used in the calibration, not beyond, and all complications in relating F_{Chla} and $[\text{Chla}]$ are valid (thus instrument reading, although having units like $\mu\text{g/L}$, must be understood as measurement of F_{Chla}).

Optical properties of fluorometers – lamp/LED wavelengths, optical filters and other components, detector sensitivity, and measuring geometry – affect the readings. Thus, if instruments are not optically identical, as it is the case between different fluorometer models, their readings differ. To illustrate this briefly, fluorescence reading is affected by the spectra of excitation light and its match with absorption properties of the sample and by the fluorescence emission spectra of sample and spectral sensitivity of the detector. If we set two types of fluorometers to show similar values using one type of sample (e.g. using a specific water sample or species) they show different values as soon as the spectral properties (i.e. species structure) of the sample changes. In the example (Figure 4.2.1.) three different fluorometers using different optics to measure Chla fluorescence have been calibrated using chlorophyte algae. Thus, for the calibration sample all instruments show the same value (scaled to one). When measuring other types of algae, with different pigmentation and fraction of Chla in PSII, the results differ. This difference is due to variable spectral match between fluorometer light source and absorption of PSII pigments. The readings from different fluorometer models are never directly comparable, and the conversion factors cannot be determined as the major cause for the difference is the unknown spectral variability in samples.

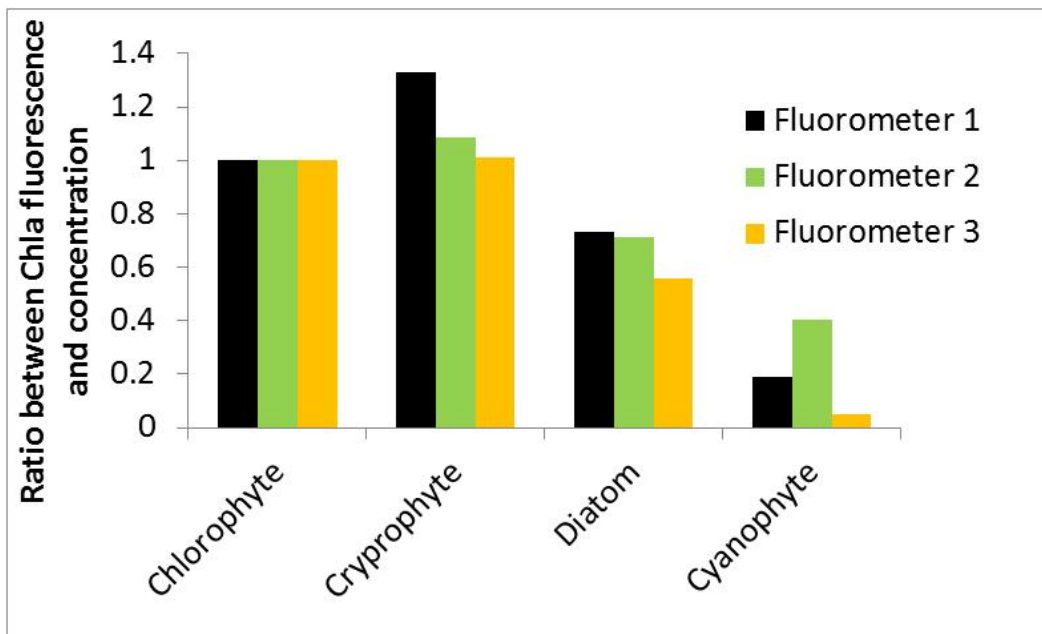

Figure 4.2.1: Ratio between Chla fluorescence and concentration measured with three optically different fluorometers. While for each instrument the ratio has been scaled to 1 for chlorophyte algae, it varies for other species due to variations of spectral match between fluorometer light source and photosystem II absorption.

Chla fluorometers use blue light to excite Chla and measure red light at the emission maxima of Chla fluorescence. Although maximum absorption for Chla is around 438 nm, typically LEDs with maximum wavelength at 460-470 nm are used, due to their availability, price, and efficiency and due to tradition. Chla itself shows only low absorption at 460-470 nm, which is more absorbed by accessory chlorophylls and carotenoids (then transferring energy to Chla). This difference between maximum absorption wavelength between Chla and the wavelengths commonly used in fluorometers slightly decreases the specificity of fluorometers for Chla measurements.

Cyanobacteria are often partly ignored when using Chla fluorometers, as most of their Chla is in the non-fluorescing PSI (see Figure 4.2.1). Although those species may have comparable amount of Chla in their cells (as measured in the laboratory using extraction methods), their abundance or variability cannot be assayed using F_{Chla} , which is often largely determined by other species (Seppälä et al 2007). Simply, even slight changes in the abundance of other species with high F_{Chla} to [Chla] ratio can mask the changes in the



cyanobacteria with very low F_{Chla} to $[\text{Chla}]$ ratio.

4.2.4. Validation of Chla fluorescence

Regularly, the preferred output from phytoplankton fluorescence studies is $[\text{Chla}]$. The working solution is to apply validation after analysing $[\text{Chla}]$ from discrete water samples taken during fluorescence measurement campaign. Sometimes, validation is carried out before or after the actual campaign using natural phytoplankton samples or cultured species, typically containing species relevant to the study area. In all cases the assumption is that the fluorescence properties of the sample used in the validation match the properties to those in study area, and that there is no large variability in fluorescence properties during the study.

The nonlinearity or scatter between F_{Chla} and $[\text{Chla}]$ is often observed and is typically not due to measurement or sampling errors but due to variations in F_{Chla} described above. Taking into account all the reasons causing fluctuations in the ratio between F_{Chla} and $[\text{Chla}]$, it is actually striking to see how well they sometimes correlate.

Linear adjustment, setting the ratio between F_{Chla} and $[\text{Chla}]$ as constant is the most often used method when converting measured F_{Chla} to $[\text{Chla}]$. Then, coefficient of determination (r^2) is used as a measure of goodness of fit. Magnitude of r^2 does not, however, tell if the ratio between F_{Chla} and $[\text{Chla}]$ varies a lot or not, as it is largely affected by the quantitative range of the observations. On the other hand, low r^2 value does not mean that ratio between F_{Chla} and $[\text{Chla}]$ varies significantly, especially in such case that the variation in the overall concentrations is low.

Several auxiliary measurements can be used as additional variables explaining the difference between F_{Chla} and $[\text{Chla}]$. As a typical example, mid-day suppression of fluorescence may be taken into account using time of the day or irradiance level as an additional independent variable in regression analyses (Figure 4.2.2.). In some cases the use of additional fluorescence channels, directed to measure accessory pigments may improve the fit. For example, in the Baltic Sea during the times of cyanobacterial blooms, F_{Chla} reflects more the eukaryotic community while phycocyanin fluorescence is more related to the biomass of cyanobacteria, and ultimately to amount of $[\text{Chl}]$ during the blooms (Seppälä et al 2007). Thus including phycobilin fluorescence may improve detection of $[\text{Chla}]$ if cyanobacteria are highly abundant. Ratio between F_{Chla} and $[\text{Chla}]$ varies due to phytoplankton physiology. In addition, the fit may be improved by including PSII



photochemical efficiency (measured using fluorescence induction technique) as an independent variable (Chekalyuk and Hafez 2011). In some cases also a nonlinear fit may be justified as it may compensate concentration specific decrease in fluorescence due to the package effect and fluorescence reabsorption.

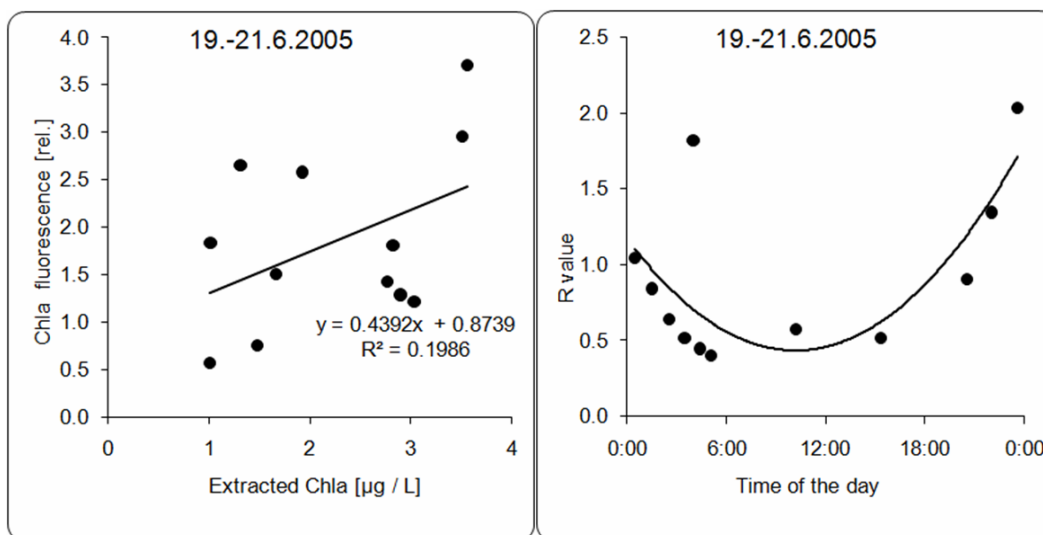

Figure 4.2.2: Scatter between F_{Chla} and $[Chla]$ measured in Ferrybox system between Helsinki and Travemünde (left) and the dependence of the ratio between F_{Chla} and $[Chla]$ (R) on the time of the day, or irradiance level (right).

4.2.5. Calibration of Chla fluorometers

The aim of primary calibration is to provide a solid reference point, to which all fluorescence measurements can be related to and which serve as reference when the performance of instrument is monitored. As fluorescence is measured in arbitrary units, the calibration will not yield a direct measurement in physical units, but to provide traceability, the material used in calibration must have a constant quantum yield. There are many additional requirements for perfect fluorescence standard (Table 4.2.1.)



simple to use
sufficiently stable in solution or as a solid
absorbs and emits in the same general regions as the compounds under study
constant fluorescence quantum yield
reveals a negligible small temperature dependence of its fluorometric properties
easy to purify/manufacture
dissolves in solvent compatible with field fluorometers
inexpensive
nontoxic, noncorrosive
traceable
reveals a negligible small pH dependence of its fluorometric properties

Table 4.2.1: Characteristics of perfect chromophore-based fluorescence standard.

Even if the validation of F_{Chla} is done properly, the need of primary calibration is not eliminated, rather contrary. The purpose of primary calibration is to guarantee that fluorescence values measured at given time can be directly related to the values measured at other times. Primary calibration, with frequent maintenance check-ups, allows comparison of fluorescence values between cruises and deployments, between seasons and years and between instruments (with same optical setup) in different platforms. After the calibration has been accomplished, the ratio between F_{Chla} and $[\text{Chla}]$ can be studied in more detail while pooling more and more measurements and auxiliary variables in the same data-set, eventually leading to better estimation of $[\text{Chla}]$ and the need for less discrete measurements.

Unfortunately there exist no generally accepted method for fluorometer calibration and also manufacturers have different conventions. Various solutions for primary fluorometer calibration include factory calibration, use of algae cultures, chemical standards dissolved in water or in various solvents, or solid standards.

Factory calibration provides typically a certificate of calibration, often meeting requirements of auditing bodies (e.g. ISO9001). Sending the instrument to the factory allows also check for and repairs of additional failures of the instrument. Factory calibration is, however, often relatively expensive and time consuming. In addition it does not always guarantee suitability or traceability of calibration material. Importantly, if factory calibration is used, the user should be able to follow reliably the instrument performance anyhow, to be able to determine quality of collected data.



Algae cultures may be used in calibration, though this should not be considered as primary calibration (Figure 4.2.3.). Living cells have variability in their ratio between F_{Chla} and $[\text{Chla}]$, which cannot be standardized. The variability exists within one species depending on the light conditions used in the cultivation, light conditions during sample storage and measurements, on the nutritional state of the cells and even on the time of the day. In addition, there is no traceability in the fluorescence of algae cultures. They also require specific infrastructure to be maintained and are not very applicable for calibration checks in platforms. On the positive side, calibration with algae cultures may be directly used as a proxy when converting F_{Chla} to $[\text{Chla}]$. They also provide realistic check of instrument performance in measuring chambers.

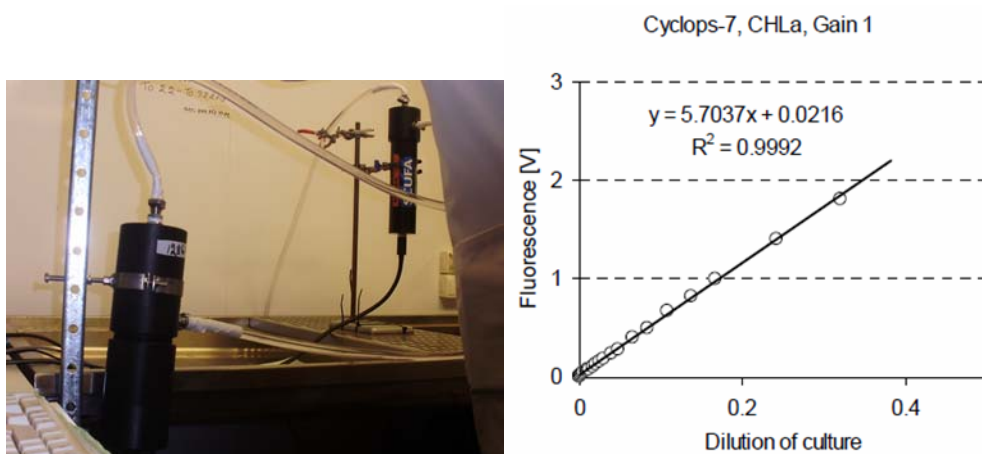

Figure 4.2.3: (Left) As flow through system used in fluorometer calibration in Finnish Environment Institute. Algae cultures are pumped simultaneously through several fluorometers allowing direct comparison of readings while using the setup similar used in Ferryboxes. **(Right)** Linearity of Chla fluorometer as tested with algae cultures. Strictly, the observed calibration coefficient (slope) is only valid for the species used in the test and for the moment of calibration.

Chemical standards provide a good alternative for cultures in primary calibration. Typically in fluorometry, calibration is carried out using the analyte itself; however this is not feasible in the case when measuring fluorescence of living algae. Finding the suitable alternative is not straightforward, and all the requirements in Table 4.2.1 are hard to fulfil. The obvious candidate for standard is purified Chla. It is not, however, stable in water solutions. Some fluorometers are compatible with organic solvents, and then Chla dissolved in acetone



or ethanol may be a good solution. Several instruments, having plastic parts or o-rings, may not be compatible with these solvents and other solutions are needed. Other chemicals, like fluorescein, have been used but sometimes they are not stable or they do not match with the wavelengths of Chla thus not yielding a good calibration.

Secondary standards can be made using fluorescence glass or chromophores in resins. The standard is fixed in the block, which will be mounted in the optical head of the instrument for measurements. They may provide a stable and traceable signal allowing tracking the performance of instruments. Such systems are always instrument-type specific and cannot be used interchangeably between various instruments. Indeed, as each instrument is a unique, solid secondary standard does not allow direct instrument-instrument comparison. A typical example is shown in figure 4.2.4, where secondary standard readings between instruments vary a lot, while the measurements from algae suspensions show comparable results. Simply, secondary standard can be used to track the performance of single instrument, but due to even slight changes in measuring geometry between different instruments, the results may vary. When the same set of instruments are compared with water samples, with much larger and open sampling geometry, the values converge.

The best solution for primary calibration is still under scrutiny, after 50 years of the method in use. The solution should fulfil major requirements set in table 4.2.1. In table 4.2.2, the various methods for calibration are compared, against these requirements. The outcome would allow converting raw fluorescence results obtained from the fluorometer to the traceable values of the standard. The second issue, validation with field samples, may be much simpler than today, if we could rely that the vast fluorescence data-sets have a common traceable reference.

Even after a perfect fluorescence standard for Chla has been obtained, unfortunately not all of the problems will be solved. The comparison of various instruments with different optics is a key issue and the next question to be raised is, can we (or should we) standardise optical setups, and what are the implications for instrument development.

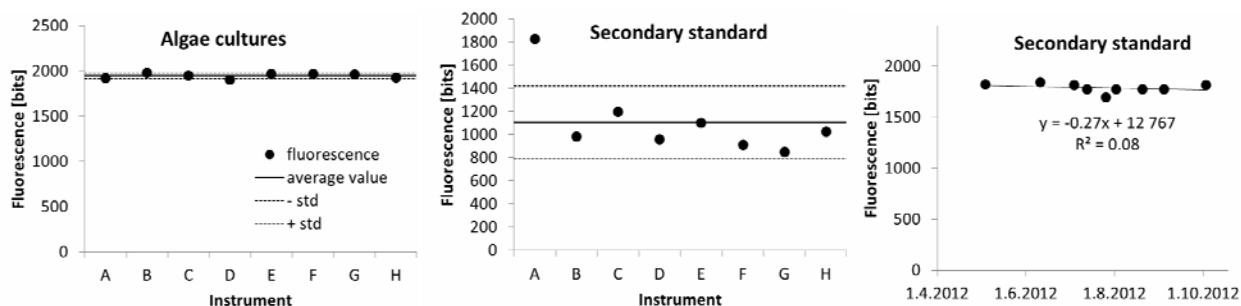

Figure 4.2.4: Fluorescence readings of 8 fluoroprobes using algae cultures (left) or solid secondary standards (middle). Measurements are done after instruments have been calibrated. Results highlight that solid secondary standards cannot be used in direct instrument comparisons. However, the example (right) shows their value in following the performance of single instruments. In this example, the fluoroprobe has been continuously used in FerryBox system and the performance of fluoroprobe has been tested semi-weekly with solid secondary standard, showing reasonable stability of the instrument.

	simple to use	stable fluorescence	spectral match	compatible	transferable	cost	traceability	flexible
Factory calibration	-	+	+	+	+	-	?	-
Algae culture	-	-	+	+	+	-/+	-	-
Chla in solvent	+(-)	+	+	-/+	+	+	+	+/-
Fluorescein	+(-)	-	-	+	+	+	+	+/-
Chla in water	-	-	+	+	+	+	-	-
Solid standard	+	+/(?)	+	+	-	+	+/?	+

Table 4.2.2. Suitability of various methods for calibration of chlorophyll fluorometers. Criteria included: technical simplicity of the use, stability of the calibration material fluorescence yield, spectral match between calibration material and chlorophyll, compatibility of the calibration materials (e.g. solvent) and fluorometers, transferability of the calibration results from one instrument to another, cost of the calibration, traceability of calibration materials, and flexibility of the methods, e.g. for the use in field studies.



4.2.1. Calibration Best Practice recommendations

- Method of calibration (see table 4.2.2.) should be selected taking into account instrument type, its compatibility and need for field checks. Use of two or several methods in calibration will increase the traceability.
- Sensors should be visually inspected and cleaned before calibration.
- Calibrations must be carried out in constant temperature.
- It is recommended to record fluorescence values with the calibration methods before any coefficients are changed and compared to previous values to assess instrument stability and need for new adjustment.
- If factory calibration is to be overwritten, user must understand the meaning of calibration procedure. An alternative for changing instrument internal calibration coefficients is to include the new coefficients in data logging or processing software only.
- Manufacturer's recommendations in the calibrations should generally be followed.
- Calibrations must be made with minimum amount of background light. The effect of light on fluorescence readings should be checked.
- If calibration is done using liquids, glass beakers should be used as plastic materials may cause background fluorescence. Black non-fluorescing material should be used under the glass beakers.
- Calibration using the field housing should be preferred.
- Cleanest possible water must be used to check blank values. Care must be taken that blank values are not below zeroed fluorescence values. Such cases will increase the detection limit of instruments.



- Linearity for the whole measuring range must be checked.
- Materials and methods used in the calibration must be carefully documented. All the coefficients and results obtained must be stored.



4.3. Chemical sensors

Chemical sensors measuring chemical parameters (e.g. NH_4 , NO_2 , NO_3 , SiO_4 and o-PO_4) need frequent calibration and validation with in-situ samples in order to have a satisfactory quality. This is due to deterioration of chemicals, interference with other substances in the water (seasonal or spatial) and other factors.

Nitrate, Phosphate, Silicate and Ammonium are the most interesting dissolved nutrients (in descending order) that are currently monitored in European waters. They are also of special interest in estuaries and coastal oceans (Duda et al., 2005). Calibration of chemical sensors is agreed to be one of the key aspects of operational measurement of chemical parameters, and most institutions are conducted their own calibration routines. Commercial available measurement devices (e.g. EcoTech NUT, Systea Micromac) are able to measure all four parameters. Others are specific for only one parameter (WET labs Cycle P). A device example is shown in Figure 4.3.1.





Fig. 4.3.1: Chemical sensor example: the Systea Micromac-1000.

It is the intention here to describe the general aspects of the calibration procedures that have to be done throughout the calibration process. Then, we will go into details for the nutrient parameters Nitrate, Phosphate, Silicate and Ammonium.

4.3.1. General aspects of best practises

- Preparing of standard solutions

For the controlling of chemical sensors, standard solutions are prepared before the calibration process in the lab. The accuracy of the preparation of the standard solution is critical. Two methods for preparing a standard can be applied. Since laboratory scales are getting more accurate, the gravimetric method could be used. The second one is the volumetric method, which is strongly dependent of the temperature. A constant temperature of 20°C has to be complied. To achieve high quality measurements the salts must be dried and ground carefully before weighing. Otherwise, errors of 2-3 % can arise (Hydes et al., 2010). To ensure the accuracy of calibrations all volumetric glass and plastics need to be gravimetrically calibrated. Because of its best stability properties, Pyrex is recommended for preparation of standard solutions. After preparation, standards should be kept in plastics containers (i.e. polycarbonates) that have a low transpiration rate for water (Hydes et al., 2010).

For each nutrient parameter, single standards can be used, or as an alternative, mixed standards (with 5 different parameters). When high consumption is expected (i.e. at repeated control cycles), single standards are recommended.

Different parameters require slightly different preparation details, as e.g. different analytical-grade preservatives have to be used. As an example, for Nitrite, sodium nitrite is recommended whereas for Nitrate potassium nitrite is best practise. For Nitrite, no acid or mercury is allowed as a preservative, as they accelerate nitrite loss (Aminot and Kerouel, 1996).



For getting best results, the use of (artificial) seawater standards with comparable salinity is recommended; however, they are more complex to prepare. Alternatively ultrapure water standards can be used.

When using more than one concentration, the calibration should be started with the lowest concentration to avoid carry-over effects.

- Reagents

Problems with reagents purity should be minimised by using “Analytical Grade” reagents. Small amounts of contamination can be tolerated, as they will produce a constant offset in the reagent baseline, which equally affects samples and standards. The reagent absorbance relative to water should be measured regularly. In general, the higher the reagent absorbance, the higher the detection limit of the method (Hydes et al., 2010).

For the preparation of reagent solutions, it is recommended to record when and from what source each batch of reagent was prepared and the time and date when its use begun. Such information can be invaluable for tracing sources of problems arising from improperly formulated or weighed reagents. Reagent containers should be convenient to use and easy to clean. When measuring silicate the use of glass should be kept to minimum to avoid silica contamination by glass dissolution (Zhang et al., 1999).

Tap water must never be used because of the high levels of Si and NO₃ it usually contains. Instead, pure water is recommended. In some laboratories atmospheric ammonium can cause contamination problems, as ammonium usually shows only small concentrations. Regular cleaning of storage containers reduces variance in the analytical results, as reagents degrade more slowly in well-maintained bottles than in dirty ones (Hydes et al., 2010).

The stability of colour forming reagents often varies greatly. It depends on the reagent itself, the observation location and other surroundings like the temperature stability, light exposure and contact with oxygen (air). Thus, it is recommended to store the reagents in constant tempered and tightly closed bottles in the dark. Then, reagents remain stable for at least 3-4 weeks and the chemical buffer solutions even



longer.

Before running the nutrient sensor device with reagent probing, a blank probing only with reagent should be done to determine the zero line.

- Bottle samples and laboratory analysis

Bottle samples are taken at the observation station for later analysis in the laboratory. The largest errors of sample analysis occur in poor choice of sample container and inappropriate storage. The best way is to use sample bottles once only (Hydes et al., 2010). The best way is to analyse immediately bottled nutrient samples. However, if the storage time does not exceed a time interval of more than three days, only cooling of the sample is possible. Beyond that, the samples should be frozen and then given sufficient time for defrosting. In case of Silicate, the defrosting period should take at least 24 hours at room temperature. The overall routine is even more sensitive when analysing Ammonium as concentrations are generally low and maybe are even more biased by longer storage.

Nutrient samples are analysed in the laboratory normally by analysis devices, e.g. the Autoanalyser (AA3) (Figure 4.3.2). It is a continuous flow-analyser with many applied different wet-chemistry analysis methods. It provides fully automatic analysis of liquid samples. Small quantities of standard solutions and samples are aspirated by a sampler and transmitted through the complete system by means of a peristaltic pump.

The continuously flowing liquid stream is then divided into segments by introduced bubbles into the flow. In the segments, the sample is then mixed with reagents while each segment has same surrounding conditions.

A characteristic of segmented-flow systems is their ability to operate in steady-state mode, where the absorbance of the reaction stream is not changing with time.

A curve of the detector output of a sample flowing through the flow-cell has the typical shape as shown in Figure 4.3.3. The concentration is constant between the time t_1 and t_2 . The signals received during this time are used to calculate the sample concentration.

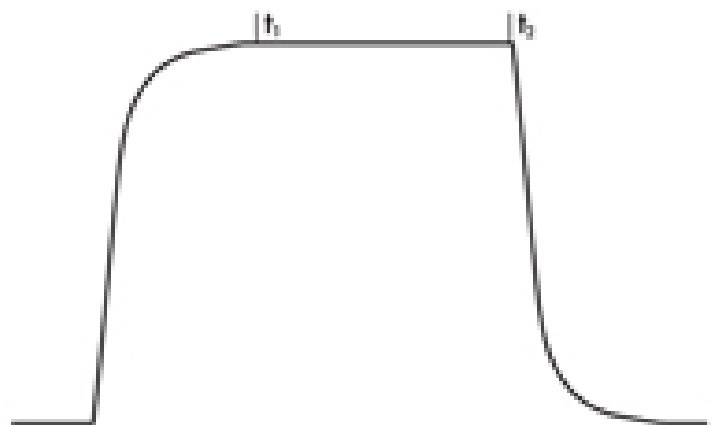

Fig. 4.3.2: Autoanalyser AA3, from Bran & Luebbe (left). Steady-state plateau on peaks (right).

4.3.2. Nitrate

Nitrate is the one of the most important and, consequently, most frequent measured nutrient parameter. Direct measurement of Nitrate (NO_3^-) is not possible; it has to be reduced to Nitrite (NO_2^-). Two methods for measurement of Nitrite are commonly applied.

- UV Absorption

Measurement of UV absorption at 220 nm with a spectrophotometer enables rapid determination of NO_3^- without chemicals. Details could be found e.g. by Armstrong (1963).

- Colorimetric determination after reduction to nitrite

The cadmium reduction method is a colorimetric method that involves contact of the nitrate in the sample with cadmium particles, which cause nitrates to be converted to nitrite and is modified based on



Grasshoff (1976). The nitrites then react with another reagent to form a red color whose intensity is proportional to the original amount of nitrate (EPA, 2012). The reduction capacity of the Cadmium reductor has to be checked regularly. When the reduction efficiency is depleted (below 90%), the reductor has to be replaced (Hydes et al., 2010). Nowadays also the reduction of nitrate by UV light is used in some analysers.

4.3.3. Silicate

The method for determination of Silicate is a modification of the colorimetric method of Grasshoff (1983). Silicomolybdic acid is reduced to silicomolybdous acid by using ascorbic acid. Silicate bottle samples should be stored only in plastic bottles (i.e. PP/PE), not in glass bottles because of silicate contamination (see above). Ion exchanger for measurement of Silicate show generally different stability and, thus, different lifetime. When the critical date is reached it could be recognized by unreal high silicate values. Then, the cartridge has to be replaced.

4.3.4. Phosphate

The phosphate analysis is in principal a modification of the colorimetric method of Murphy and Riley (1962) method. Molybdic acid is added to the seawater sample which reacts to phosphomolybdic acid to phosphomolybdous acid. L-ascorbic acid is used as a reductant (Hydes et al., 2010).

4.3.5. Ammonium

For the determining of Ammonium concentration in seawater, three different methods are currently applicable. The **Salicylate method** is described e.g. by Bower and Holm-Hansen (1980) and is used for instance in the Autoanalyser AA3. This method is also applied in the chemical analyser from the company Systea (Italy). The **Fluorescence method**, described e.g. in Holmes et al. (1999) is also applied to Ammonium observations. It is



much more sensitive but also very stable method.

For the use of one measurement device for more than one parameter one has to be aware of alkaline (Ammonium) / acidic (Nitrate, Phosphate, Silicate) solutions. So, the use of two devices is recommended, one for Ammonium measurements, one for the other three parameters.

4.3.6. Nutrient calibration example

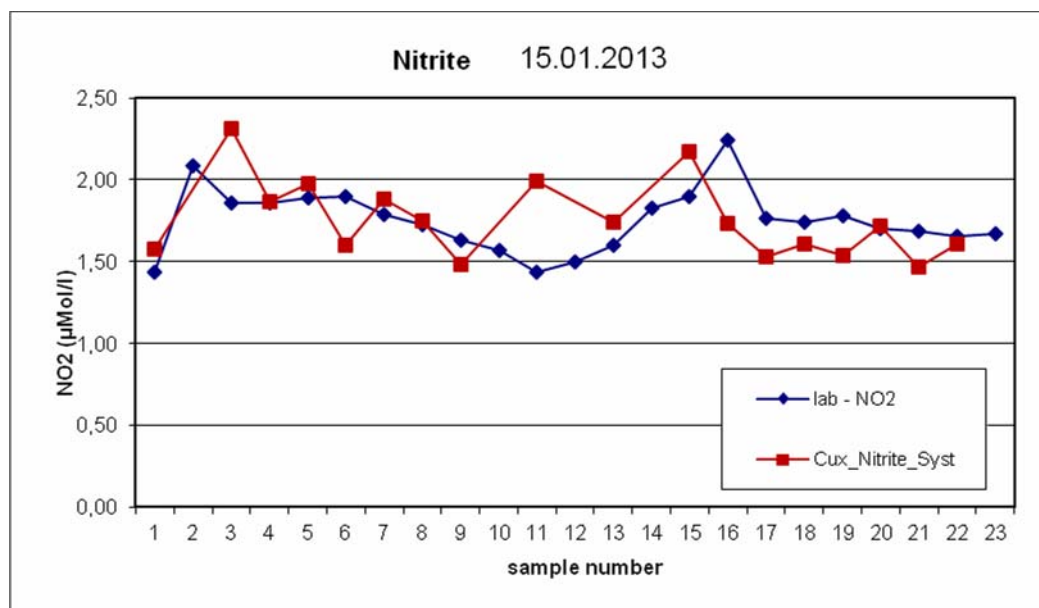

Fig. 4.3.3: Nitrate/Nitrite calibration for FerryBox Cuxhaven Container.

In Figure 4.3.3, an example of calibration routine for Nitrite measurements is shown. Bottle samples have been taken on 15 January 2013 at stationary FerryBox in Cuxhaven Container, Germany, parallel to routine nitrite observations of Systea sensor. Samples and Systea observations agree to each other as nitrite levels range for both around 1.5 to 2.5 $\mu\text{mol/L}$.

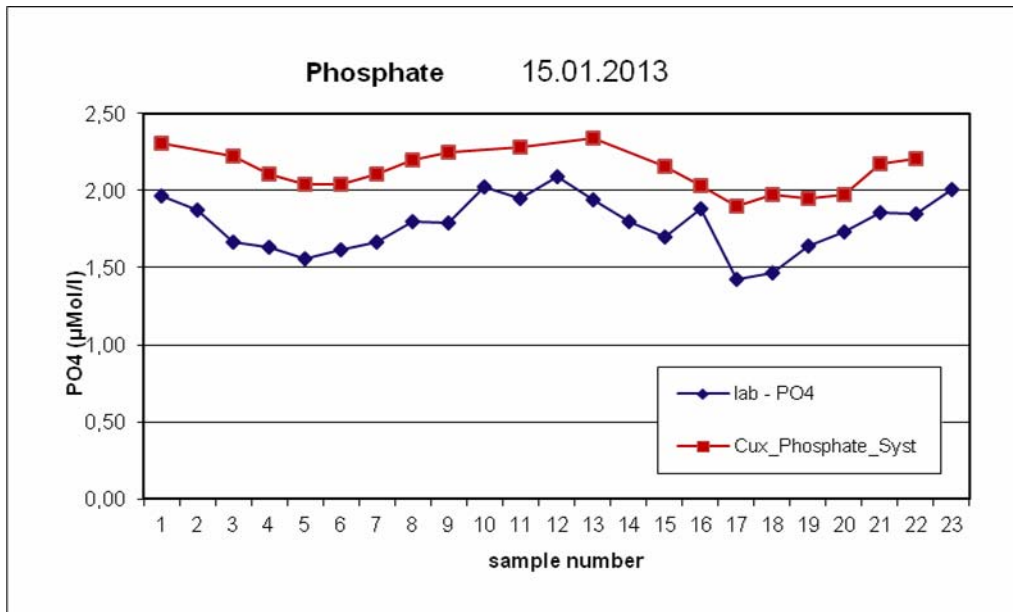

Fig. 4.3.4: Phosphate calibration for FerryBox Cuxhaven Container.

The same procedure has been performed for phosphate observations. The comparison of bottle sample analyses and Systea measurements are shown in Figure 4.3.4. On 15 January 2013, the phosphate level is around 1.5 to 2.5 $\mu\text{mol/L}$. It can be seen, that Systea observations are up to 0.5 $\mu\text{mol/L}$ higher than the according bottle sample analyses and have to be corrected.



4.3.1. Calibration Best Practice recommendations

- Methods of calibration should be selected taking into account instrument type, its compatibility and need for field checks. Use of two or several methods in calibration will increase the traceability.
- Sensors should be visually inspected and cleaned before calibration.
- Calibrations must be carried out at constant temperature.
- It is recommended to record values with the calibration methods before any coefficients are changed and compared to previous values to assess instrument stability and need for new calibration.
- If factory calibration is to be overwritten, user must understand the meaning of calibration procedure. An alternative for changing instrument internal calibration coefficients is to include the new coefficients in data logging or processing software only.
- Manufacturer's recommendations in the calibrations should generally be followed.
- Linearity for the whole measuring range must be checked for each instrument type at least once.
- Materials and methods used in the calibration must be carefully documented. All the coefficients and results obtained must be stored.
- After preparation, standards should be kept in plastics containers (i.e. polycarbonates) that have a low transpiration rate for water.
- For getting best results, the use of (artificial) seawater standards with comparable salinity is recommended.



- Reagent solutions are strongly recommended to be labelled with information when and from what source each batch of reagent was prepared and the time and date when its use begun.
- Reagents must be stored in constant tempered and tightly closed bottles in the dark.
- Nutrient bottle samples should be analysed immediately. Otherwise, if the storage time does not exceed a time interval of more than three days, the samples should only be cooled. Beyond that, the samples should be frozen and then given sufficient time for defrosting.
- For the procedure of measuring of more than one nutrient parameter, the use of at least two devices is recommended, one for Ammonium measurements, one for the other parameters.



4.4. Oxygen sensors

The calibration (and the adjustment, if needed) of dissolved oxygen (DO) sensors is essential to collect quality DO data. The calibration will estimate the trueness and the uncertainty of the sensor but it will also check the potential influence parameters on the data. Indeed, up to now, we still don't master all the influence parameters that can affect the measurement of optical sensor for instance. That is why it is extremely important to carefully control all DO sensors. It will also give a better understanding of the behavior of DO sensors.

Depending on the scientific uncertainty requirements, different calibration or adjustment protocols can be used from the simplest one to the more complete. However, in the present document, we will focus on the up-to-date protocol recommended to reach the best uncertainties: this protocol is composed of a multi-point calibration followed, if needed, by an adjustment in compliance with the recommendations published by Hiroshi et al. (2008).

4.4.1. Calibration and adjustment process:

The calibration protocol will be to compare the results of DO sensors immersed in water of controlled DO concentrations to reference measurements.

We are going to describe:

- The reference measurement
- The dissolved oxygen bench
- The protocol
- The adjustment process



Reference measurement

As widely accepted in the scientific community, the reference measurements should be Winkler titration.



Fig. 4.4.1: Winkler sample (with the courtesy of Ifremer).

Originally developed by Winkler in 1888 (Winkler, 1888), this method has been adopted by the oceanographic community and is recognized as the most accurate technique to determine dissolved oxygen in seawater. Over time the Winkler protocol has been largely described and improved, in several papers (most of them can be found easily on the web):

- Carritt, D.E. 1964. Intercomparison of methods in chemical oceanography. I. Precision and accuracy of the Winkler method. National Academy of Sciences- National Research Council.
- Carpenter, J. H. 1965. The accuracy of the Winkler method for dissolved oxygen. *Limnol. Oceanog.*, 10: 135-140
- Carpenter, J. H. 1965. The Chesapeake Bay Institute technique for the Winkler dissolved oxygen method. *Limnol. Oceanog.*, 10: 141-143
- Culberson, C. H. July 1991. Dissolved Oxygen WHP Operations and Methods



- DOE (1994) Handbook of methods for the analysis of the various parameters of the carbon dioxide system in sea water; version 2. A. G. Dickson & C. Goyets (eds.), ORNL/CDIAC-74
- A. G. Dickson, Determination of dissolved oxygen in sea water by Winkler titration (<http://cchdo.ucsd.edu/manuals.html>)
- Méthodes d'analyse en milieu marin, Alain Aminot et Roger Kérouel "Hydrologie des écosystèmes marins ; paramètres et analyses" (336 p.).

However, the Winkler method remains a difficult protocol to carry out, which demands skillful operators and careful practices in handling the different operations required (sampling of water, preparation of reagents, volumetric determination of flasks and devices, etc.).



Fig. 4.4.2: Winkler sampling (with the courtesy of Ifremer).



That is why we highly recommend laboratories that want to use or already use this method, to implement trials to test their protocol and ensure the quality of their Winkler titration. For example, an easy and powerful way is to attend or organize inter-laboratory comparisons.

Uncertainty estimate

In terms of quality of the measurement, the uncertainty of the Winkler volumetric method can be calculated following the Guide to the expression of uncertainty in measurement (JCGM 100:2008). It leads to uncertainties varying between ± 2 to ± 5 $\mu\text{mol/l}$ and depending on:

- the dissolved oxygen concentration of the sample to be analysed (uncertainties are combined with the volumes of reagents added)
- the operator skills and the performances of the equipment (precision terms)

However, the major component of the uncertainty comes from the uncertainty of the volume delivered by the titrator. This uncertainty component is the volumetric tolerance of the burette, which must be conformed to regulatory requirements.

4.4.2. Dissolved oxygen facility

At present time, no device recommendations are proposed; except that the dissolved oxygen facility must perform different DO concentrations.

Indeed, different kinds of bench are used all over the world (different bubbling or chemical systems), but few



laboratories are equipped (ten or so) and no facilities intercomparison was published so far. Seven of these laboratories attended the only worldwide inter-laboratory comparison organized from 2012 to 2014 in the framework of the Argo program; results are currently processed.

Several examples of facilities are listed below:

- Ifremer - France (contact person F. Salvetat)

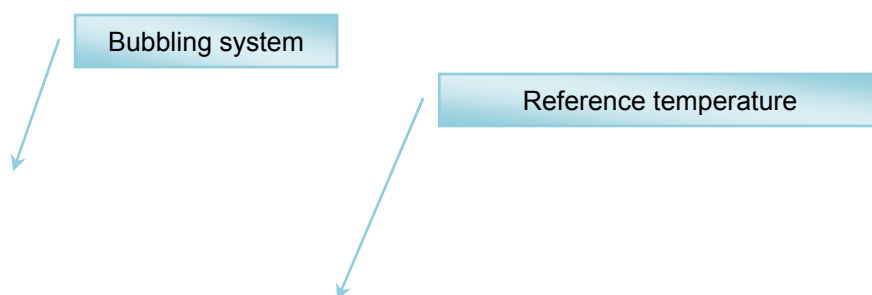

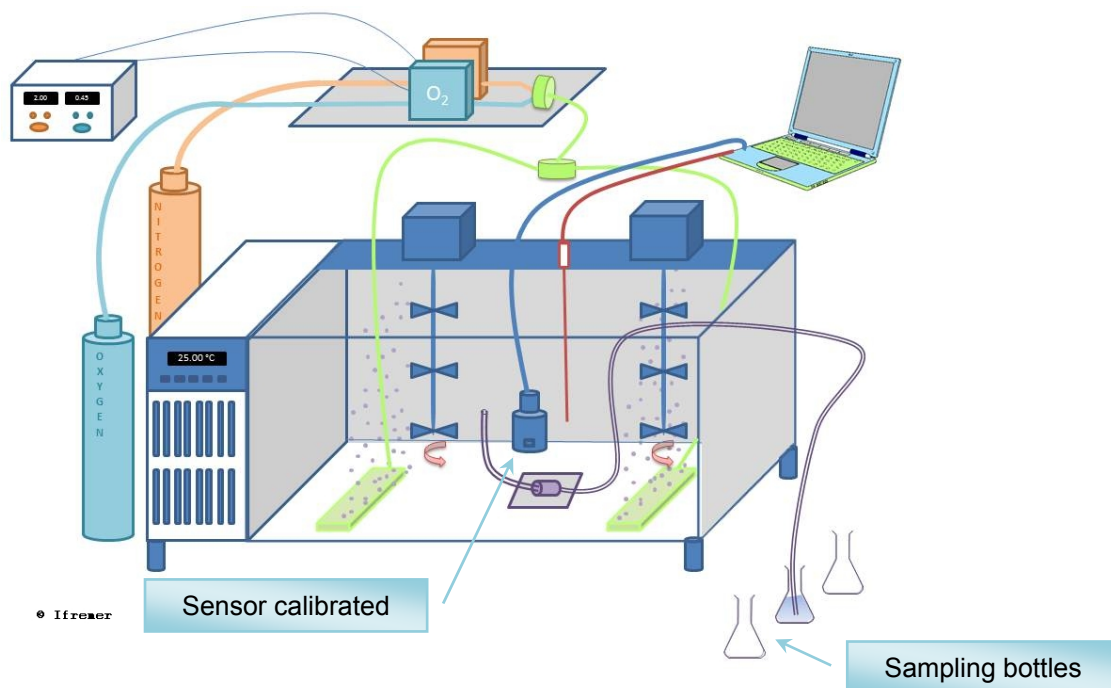

Fig. 4.4.3: Ifremer facility (with the courtesy of Ifremer).

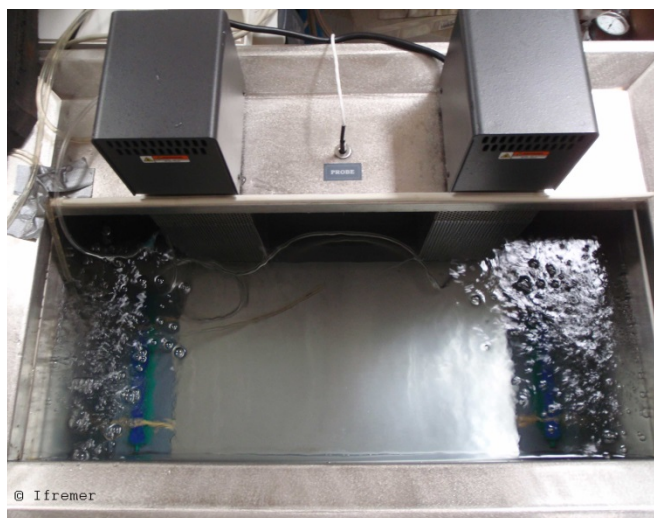

Fig. 4.4.4: Ifremer facility (with the courtesy of Ifremer).



- Mediterranean Institute of Oceanography – France (contact person D. Lefèvre)

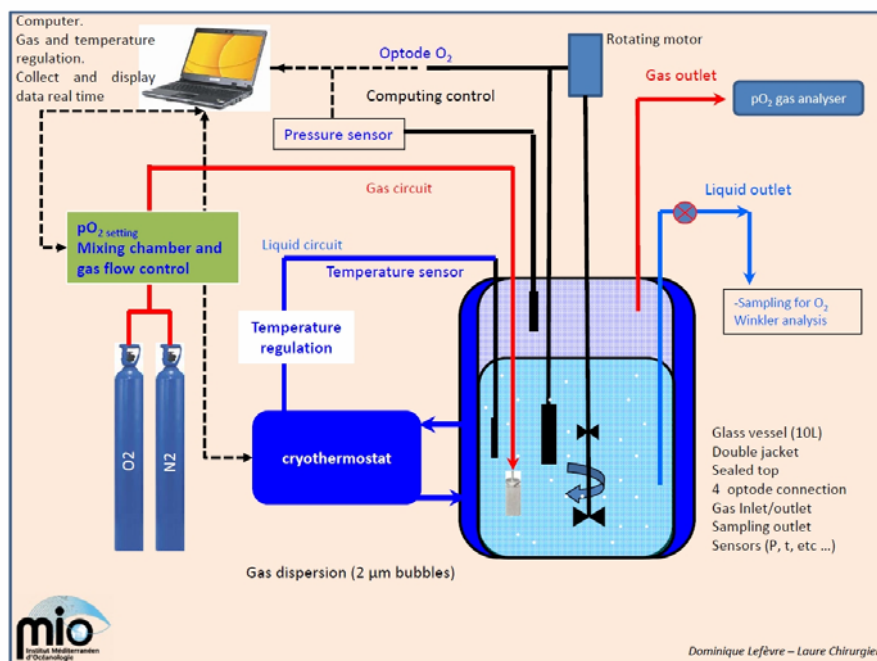

Fig. 4.4.5: MIO SCALOO facility.

SCALOO: Calibration station for oxygen optodes. The station is based on a thermo-regulated vessel of 10L with a continuous flow of O₂ and N₂ gases mixture. The O₂/N₂ ratio and temperature are automatically adjustable to 11 and 8 levels respectively based on a pre-recorded matrix. A labview® based software monitors the dynamics and collects environmental variables (mixing rate, pressure, etc.) of the station as well as the data at a set frequency (30s). Data analysis is made at posteriori.

- Geomar – Germany (contact person H. Bittig)

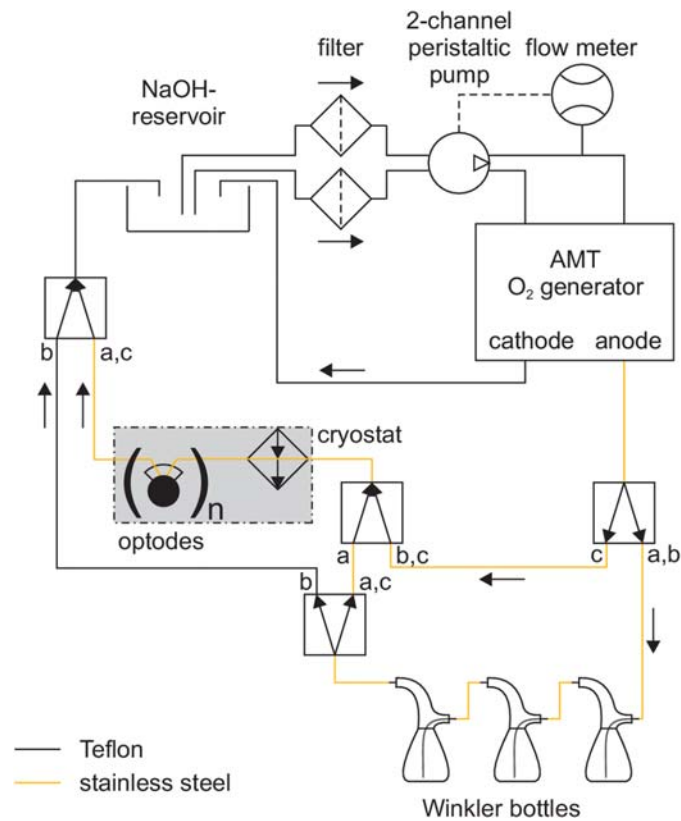

Fig. 4.4.6: Geomar facility (Bittig et al., 2012).

- Max-Plank Institute – Germany (contact person F. Janssen)

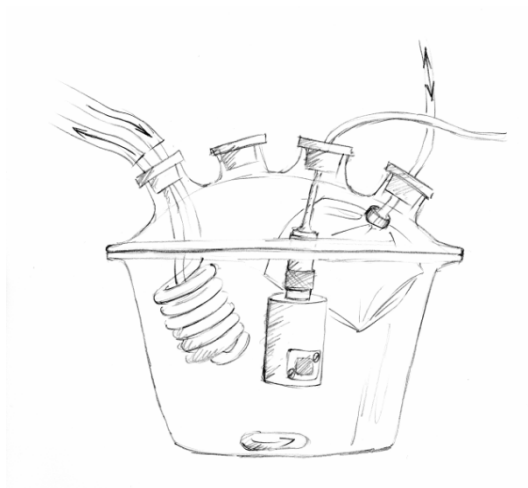

Fig. 4.4.7: MPI facility.

- Aanderaa Data Instruments AS – Norway (contact person J. Hovdenes)
- Commonwealth Scientific and Industrial Research Organisation – Australia (contact person C. Neill)
- Japan Agency for Marine-Earth Science and Technology – Japan (contact person H. Uchida)

Uncertainty estimate

Whatever bench is used, it is necessary to characterize it in order to define its uncertainty components. We remind that usually the main components are stability and homogeneity. However, other characteristics can be investigated in order to make the use of the bench easier.

As an example, we indicate here the characteristics of Ifremer bench:

- Stability is lower than $\pm 0.5 \mu\text{mol/l}$ within 1 hour



- The stability can last several hours
- The lowest concentration achieved is near 0% and saturation up to 140% where achieved
- Homogeneity is lower than $\pm 2 \mu\text{mol/l}$

These specifications will contribute to the uncertainty budget of the calibration of the sensor.

4.4.3. The protocol of calibration

The calibration will be carried out over the range of dissolved oxygen measured *in situ*. Depending on the width of this range, several calibration concentrations will be done (including the extreme points of the range) at different temperatures corresponding to the range of temperature measured at sea.

In case of adjustment, the calibration program needs also to be defined in accordance with the adjustment equation. An example of program for Uchida adjustment can be:



Temperature	DO%
0°C	0%
	20%
	60%
	100%
	135%
10°C	0%
	20%
	60%
	100%
	135%
15°C	100%
20°C	0%
	20%
	60%
	100%
	135%
30°C	0%
	20%
	60%
	100%
	135%

Few points can be repeated twice or more in order to check the reliability of the results.

Uncertainty estimate

The uncertainty of the calibration is calculated combining the uncertainties components of the Winkler, of the bench and of the sensor as recommended in the Guide to the expression of uncertainty in measurement. When an adjustment is proposed, the uncertainty components related to the way the sensor was adjusted are added to calculate the final adjustment uncertainty.



Comments:

If needed, a specific expertise of the sensor response with regard to pressure could be also done (Tengberg and Coauthors, 2006). However, this application needs specific pressure facilities, which are beyond of the scope of this document.

4.4.4. The adjustment process

The adjustment is performed following the publication of Hiroshi et al. (2008). Uchida proposes to reformulate the measurement principle of the optodes by an equation related to the physical principle of the optode: he expresses dissolved oxygen concentration as a function of the luminescence decay time and the Stern-Volmer constant. Finally, it comes:

$$[O_2] = \frac{\frac{P_0}{P_c} - 1}{K_{sv}}$$

With:

$$K_{sv} = c_0 + c_1 t + c_2 t^2 \text{ (Stern-Volmer constant)}$$

$$P_0 = c_3 + c_4 t \text{ (phase shift in the absence of } [O_2])$$

$$P_c = c_5 + c_6 P_r \text{ (corrected phase shift)}$$

$[O_2]$ = dissolved oxygen concentration in $\mu\text{mol/L}$

t = temperature in degrees Celsius

P_r = raw phase shift in degrees

C_x ($x = 0, 1, \dots, 6$) = calibration coefficients



Several methods can be used to calculate the seven coefficients:

- revised quasi-Newton method (proposed by Uchida et al. (2008))
- Nelder-Mead simplex method (Nelder and Mead, 1965)
- genetic or evolutionary algorithms

4.4.5. Example of results

Here is an example of results that can be obtained when calibrating and adjusting an optode following the protocol proposed (this adjustment was performed with Ifremer facilities).

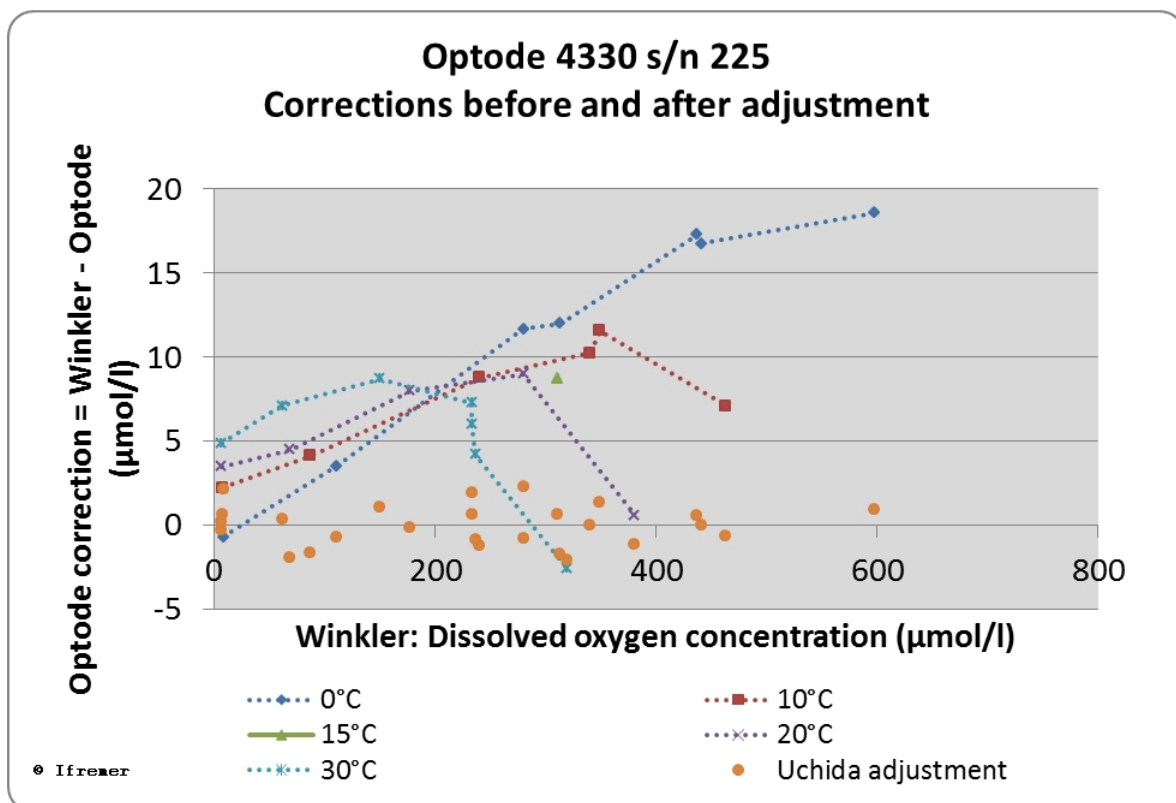

Fig. 4.4.8: Example of optode calibration and adjustment at Ifremer facility.



We can see on the graph that several calibration curves appear depending on temperature. After adjustment, the residuals are no more linked to temperature. They are lower than $\pm 3 \mu\text{mol/l}$ that proves that the adjustment is appropriate.

As explained above, the uncertainty budget for this optode adjustment varies depending on dissolved oxygen concentration. The uncertainty can be fairly well estimated to be in the range $\pm 4 \mu\text{mol/l}$ to $\pm 6 \mu\text{mol/l}$.

4.4.1. Calibration Best Practice recommendations

- The proper calibration of dissolved oxygen sensors requires expertise, specialized equipment and procedures, dedicated staff, and most of all experience. If these resources are lacking in-house, it is better to send the sensors to the manufacturer for calibration or avail of an external provider of similar services.
- All the elements of the reference measuring systems must be maintained to within declared specifications by monitoring their performances regularly, adhering to recommended usage and upkeep practices, and scheduling servicing with a manufacturer immediately when laboratory quality assurance procedures indicate a developing problem.
- The dissolved oxygen reference measurements (e.g. Winkler analyses) should be regularly checked through Inter Laboratory Comparisons (ILC).
- All the information needed to understand the way reference measurement was obtained must be documented and stored to ensure traceability (equation used, parameters of the titrator, values of blanks, etc.)



- Sensors should be visually inspected prior to calibrating.
- The dissolved oxygen calibration facility should be allowed to settle at a calibration set-point for a sufficient period of time (an hour or more) before sampling is initiated. The stability of the bath should be continuously monitored during the sampling interval.
- The calibrated sensors should be checked at least at a few calibration set-points prior to releasing them for duty.
- In principle, reference O₂ measurements could be acquired using internal transfer standards (for example, a O₂ sensor) in lieu of a analytical reference measurement, provided traceability to the appropriate primary standards has been established and the quality of readings are compatible with the degree of uncertainty required for calibrating.
- Marine O₂ sensors require regular, often frequent, calibrations because their performances tend to vary over time and can be affected by the specific conditions of usage and storage. Sensor calibrations need to be verified at least once a year.
- Proper field maintenance is the key to successful calibrations. Poorly maintained instruments often need to be subjected to long and complicated procedures in order to restore them to a condition that would permit a proper calibration to be performed.
- In the case of modular O₂ sensors, sensor calibrations must be performed, whenever possible, employing the main housing containing the electronics of the instrument to which they belong.
- Sensors should be subjected to an “as received” evaluation of their performances prior to adjustment. The information thus obtained could be useful for adjusting already collected data to account for sensor drift or errors during deployment.



- It may be useful to occasionally employ a calibration service provider different from the usual one; for example, if calibrations are routinely performed in-house, they could be done externally every once in a while. Over time, this custom will provide information useful for quality assurance.
- Calibration records must be kept up-to-date; calibration histories of sensors can often help to pre-empt potential problems with them in time.
- The results of a calibration may or may not be accredited but they must always be accompanied by the following:
 - A declaration of the uncertainty associated with the calibration process;
 - Information evidencing traceability to reference material (certified or otherwise).



5. Conclusions

This report is a contribution to task 4.1 of work package 4 of EU project JERICO. The objective of work package 4 is to improve the performance of JERICO observatories and the overall quality of products which are delivered by project partners. One step consists on a survey of the best practise for sensor calibration. The sensor calibration is a sensitive task and strongly dependent on the sensor type. Thus, we distinguish explicitly between different types, i.e.

- Physical sensors,
- Optical sensors,
- Chemical sensors,
- Oxygen sensors.

However, the calibration of sensors needs in general a high level of

- Experience of personnel
- Regular training of personnel
- Sensitive and careful handling of sensor calibration facilities
- Regular sensor calibration before (and after) deployment



Going into detail, the different sensor types demand different best practises of sensor calibration. In the previous chapters, several advices for each sensor type have been formulated. The most important features are:

- As temperature sensors cannot be calibrated in the field, it is even more important to perform a thorough calibration routine in the lab.
- It is well acknowledged that F_{Chla} measurements do not reflect true analytically measured $[\text{Chla}]$, due to various reasons. Linear calibration, setting the ratio between F_{Chla} and $[\text{Chla}]$ as constant is the most often used method when converting measured F_{Chla} to $[\text{Chla}]$. In some cases the use of additional fluorescence channels, directed to measure accessory pigments may improve the fit.
- For the controlling of chemical sensors, standard solutions are prepared before the calibration process in the lab. The accuracy of the preparation of the standard solution is critical.

For getting best results, the use of (artificial) seawater standards with comparable salinity is recommended.

For the preparation of reagent solutions, it is recommended to record when and from what source each batch of reagent was prepared and the time and date when its use begun.

The stability of colour forming reagents often varies greatly. It depends on the reagent itself, the observation location and other surroundings like the temperature stability, light exposure and contact with oxygen (air). Thus, it is recommended to store the reagents in constant tempered and tightly closed bottles in the dark.



The largest errors of sample analysis occur in poor choice of sample container and inappropriate storage.

The best way is to analyse immediately bottled nutrient samples. However, if the storage time does not exceed a time interval of more than three days, only cooling of the sample is possible.

- Depending on the scientific uncertainty requirements, different calibration or adjustment protocols can be used from the simplest one to the more complete. However, in the present document, we will focus on the up-to-date protocol recommended to reach the best uncertainties: this protocol is composed of a multi-point calibration.

Originally developed by Winkler, this method has been adopted by the oceanographic community and is recognized as the most accurate technique to determine dissolved oxygen in seawater. Over time the Winkler protocol has been largely described and improved.

At present time, no device recommendations are proposed, except that the dissolved oxygen facility must perform different DO concentrations.

Some general advices for calibration, which are independent from the sensor type, can be formulated:

- The proper calibration of sensors requires expertise, specialized equipment and procedures, dedicated staff, and most of all experience. If these resources are lacking in-house, it is better to send the sensors to the manufacturer for calibration or avail of an external provider of similar services.
- All the elements of the reference measuring systems must be maintained to within declared specifications by monitoring their performances regularly, adhering to recommended usage and upkeep practices, and scheduling servicing with a manufacturer immediately when laboratory quality assurance procedures indicate a developing problem.



- Sensors should be visually inspected prior to calibrating.
- The temperature calibration bath should be allowed to settle at a calibration set-point for a sufficient period of time (an hour or more) before sampling is initiated. The stability of the bath should be continuously monitored during the sampling interval.
- The calibrated sensors should be checked at least at a few calibration set-points prior to releasing them for duty.
- Proper field maintenance is the key to successful calibrations. Poorly maintained instruments often need to be subjected to long and complicated procedures in order to restore them to a condition that would permit a proper calibration to be performed.
- Calibration laboratories should be able to show proof of their competences by, for example, attending or organizing inter-laboratory comparisons whenever it is possible.



Annexes and References

References:

- Aminot, A., Kerouel, R., 1996. Stability and preservation of primary calibration solutions of nutrients. *Marine Chemistry* 52, 173-181.
- Armstrong, F.A.J., 1963. Determination of nitrate in water by ultraviolet spectrophotometry. *Anal. Chem.* 35.
- Babin, M., 2008. Phytoplankton fluorescence: theory, current literature and in situ measurement. In: Babin, M., Roesler, C.S., Cullen, J.J. *Real-time coastal observing systems for marine ecosystem dynamics and harmful algal blooms: Theory, instrumentation and modeling.* Unesco, Paris, p 237-280.
- Bittig, H.C., Fiedler, B., Steinhoff, T., Körtzinger, A., 2012. A novel electrochemical calibration setup for oxygen sensors and its use for the stability assessment of Andraea optodes. *Limnol. Oceanogr.: Methods* 10, 921-933.
- Bower, C.E., Holm-Hansen, T., 1980. A Salicylate–Hypochlorite Method for Determining Ammonia in Seawater. *Canadian Journal of Fisheries and Aquatic Sciences* 37, 794-798.
- Chekalyuk, A., Hafez, M. 2011 photo-physiological variability in phytoplankton chlorophyll fluorescence and assessment of chlorophyll concentration. *Optics express.* 19, 22643-22658.
- Duda, M.D., De Michele, P.E., Jones, M., Criscione, A., Craun, C., Winegard, T., Lanier, A., Bissell, S.J., Herrick, J.B., 2005. Use of, satisfaction with, and requirements for in-situ nutrient sensors. Responsive Management National Office, Harrisonburg, VA, USA.
- EPA, 2012. *Water: Monitoring and Assessment.*
- Grasshoff, K., 1976. *Methods of seawater analysis.* Verlag Chemie, Weinheim, Germany.
- Grasshoff, K., 1983. K. Grasshoff, M. Ehrhardt, K. Kremling (Editors): *Methods of Seawater Analysis.* Second, Revised and Extended Edition.—With 108 figs, 26 tab., 419 pp. Weinheim/Deerfield Beach, Florida: Verlag Chemie 1983. ISBN 3–527-2599-8 (Weinheim) 0–89573-7 (Deerfield Beach). DM 140,00, \$ 70.00.
- Internationale Revue der gesamten Hydrobiologie und Hydrographie* 70.
- Hiroshi, U., Kawano, T., I., K., Fakasawa, M., 2008. In Situ Calibration of Optode-Based Oxygen Sensors. *J. Atmos. Oceanic Technol.* 25, 2271-2281.
- Holmes, R.M., Aminot, A., K erouel, R., Hooker, B.A., Peterson, B.J., 1999. A simple and precise method for measuring ammonium in marine and freshwater ecosystems. *Canadian Journal of Fisheries and Aquatic Sciences* 56, 1801-1808.
- Hydes, D.J., Aoyama, M., Aminot, A., Bakker, K., Becker, S., Coverly, S., Daniel, A., Dickson, A.G., Grosso, O., Kerouel, R., Van Ooijen, J., Sato, K., Tanhua, T., Woodward, E.M.S., Zhang, J.Z., 2010. Determination of dissolved nutrients (N,P,Si) in seawater with high precision and inter-comparability using gas-segmented continuous flow analysers, ICPO Publication Series.
- JCGM, 2012. *International vocabulary of metrology - Basic and general concepts and associated terms (VIM),*



in: Metrology, J.C.f.G.i. (Ed.).

Johnsen, G., Sakshaug, E. 2007. Biooptical characteristics of PSII and PSI in 33 species (13 pigment groups) of marine phytoplankton, and the relevance for pulse-amplitude-modulated and fast-repetition-rate fluorometry. *J. Phycol.* 45, 1236-1251.

Mantylaa, W., 1987. Standard seawater comparison. *J. Phys. Oceanogr.* 17, 543-548.

Millero, F.J., Feistel, R., Wright, D.G., McDougall, T.J., 2008. The composition of Standard Seawater and the definition of the Reference Composition Salinity Scale. *Deep Sea Res. I* 55, 50-72.

Murphy, J., Riley, J.P., 1962. A modified single solution method for the determination of phosphate in natural waters. *Anal. Chim. Acta* 27, 31-36.

Nelder, J.A., Mead, R., 1965. A simplex method for function minimization. *Computer Journal* 7, 308-313.

NIST, 1990. Guidelines for Realizing the International Temperature Scale of 1990 (ITS-90), NIST Technical Note. National Institute of Standards and Technology.

NPL, 2014. What is the difference between calibration and adjustment?, in: Laboratory, N.P. (Ed.), Teddington, Middlesex, UK.

Saunders, P., 1990. The International Temperature Scale of 1990, ITS-90, in: IOS (Ed.), 10 ed, Wormley, UK.

Seppälä, J., Ylöstalo, P., Kaitala, S., Hällfors, S., Raateoja, M., Maunula, P. 2007. Ship-of-opportunity based phycocyanin fluorescence monitoring of the filamentous cyanobacteria bloom dynamics in the Baltic Sea. *Est. Coast. Shelf Sci.* 73, 489-500.

Tengberg, A., Coauthors, 2006. Evaluation of a lifetime-based optode to measure oxygen in aquatic systems. *Limnol. Oceanogr. Methods* 4, 7-17.

Uchida, H., Kawano, T., Kaneko, I., Fukasawa, M., 2008. In situ calibration of Optode-based oxygen sensors. *J. Atmos. Oceanic Tech.* 25, 2271-2281.

Winkler, L.W., 1888. Die Bestimmung des im Wasser gelösten Sauerstoffes. *Berichte der deutschen chemischen Gesellschaft* 21, 2843-2854.

Zhang, J.-Z., Fischer, C., Ortner, P.B., 1999. Dissolution of silicate from glassware as a contaminant in silicate analysis of natural water samples. *Water Research* 33, 2879-2883.